

ASTECC UM1291-1

Audio / Color Video RF Modulator

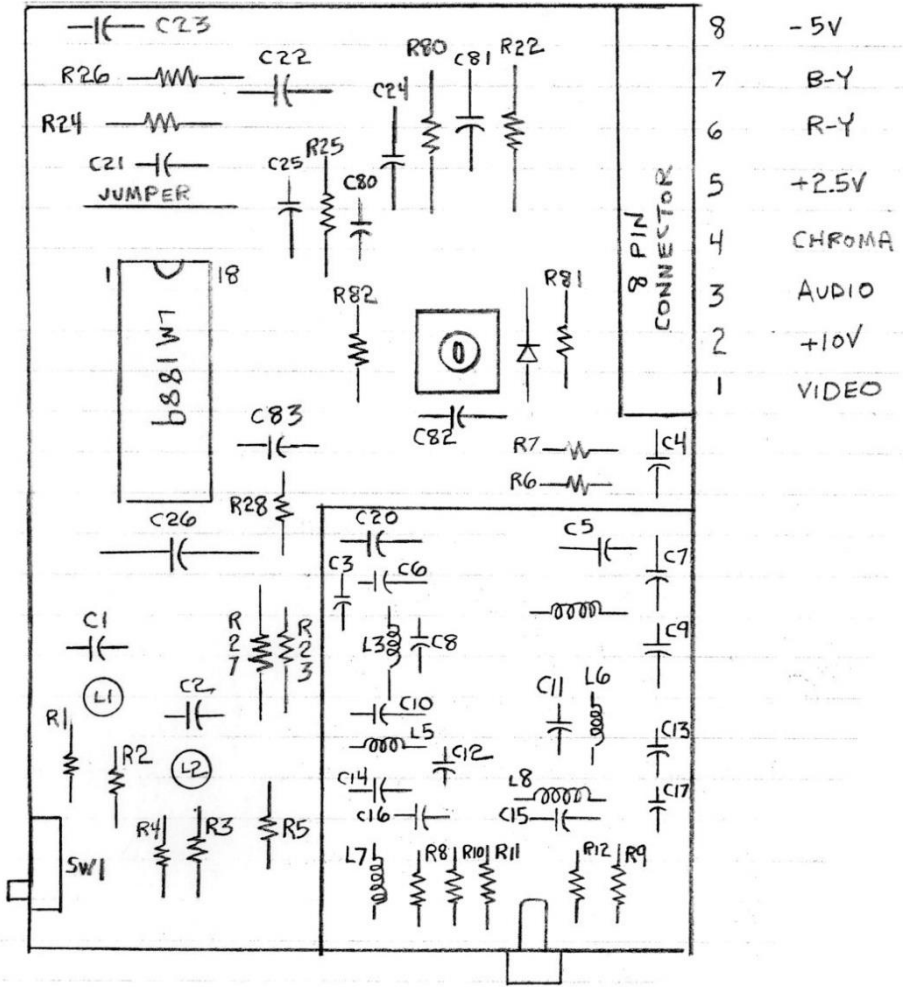

Replacement for Bally Arcade / Bally Astrocade Modulator

ASTECC UM1291-1 RF / Video Modulator

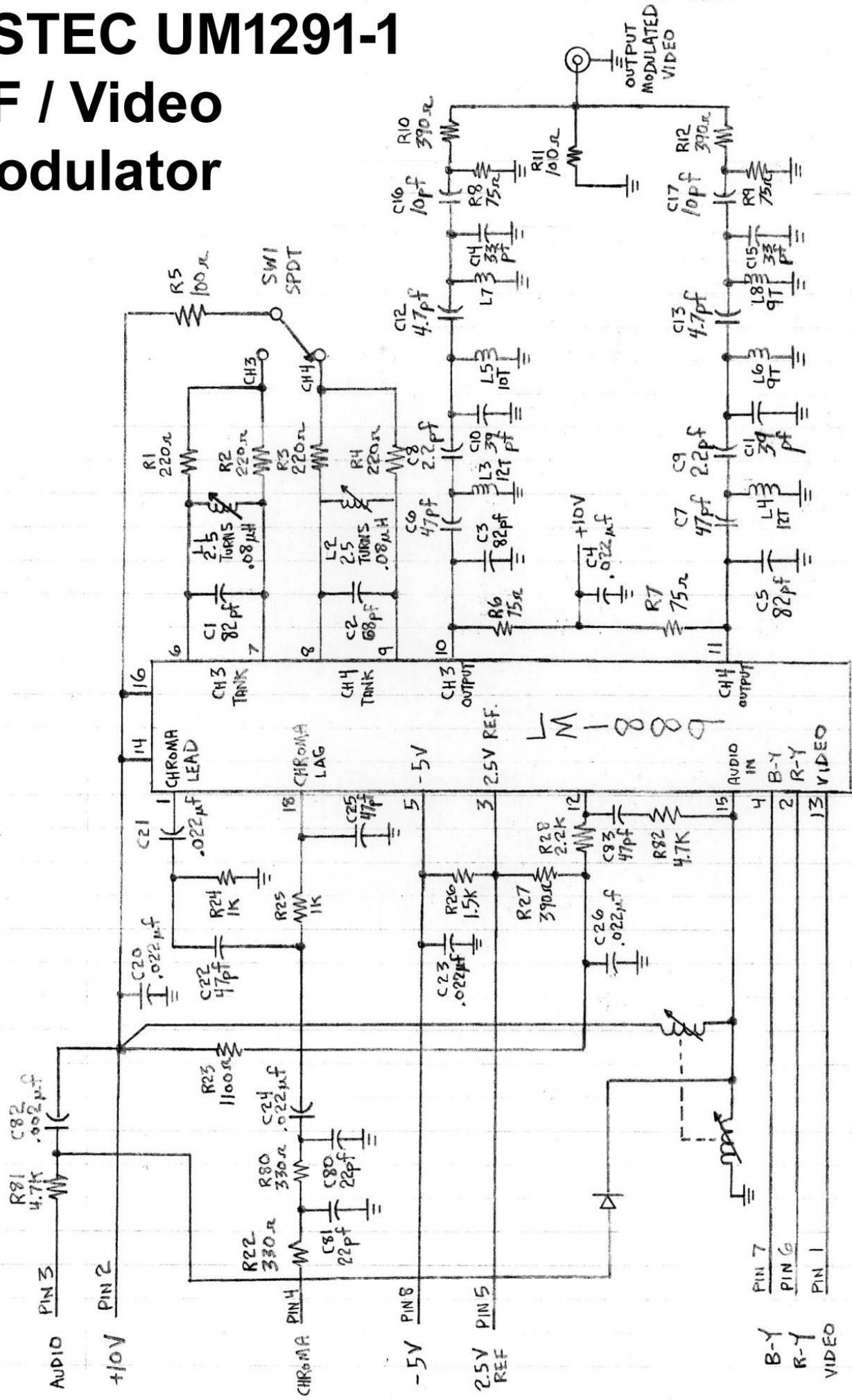

ASTECC UM1291-1
TV VIDEO MODULATOR
SCHEMATIC

BALLY MOTHERBOARD SHIELDING ←
MODULATOR METAL CASE

AN OFFSET BETWEEN PIN 12 AND PIN 13 WILL PRODUCE AN RF CARRIER AT PIN 10 OR 11 DEPENDING ON THE CHANNEL SELECTED. RF MODULATION, IN THIS CASE, IS ACHIEVED WITH PIN 12 SET AT A DC REFERENCE AND VIDEO SIGNAL APPLIED TO PIN 13.

FEEDING A CHROMA SUBCARRIER THROUGH A LEAD-LAG NETWORKS TO PIN 1 AND 18 DEFINES A QUADRATURE PHASE RELATIONSHIP BETWEEN THESE TWO PINS. THESE QUADRATURE PHASE AT PIN 1 AND 18 ARE DEFINED AS THE COLOR DIFFERENCE AXES R-Y AND B-Y. A SIGNAL AT PIN 2 (R-Y) WILL GIVE A CHROMINANCE SUBCARRIER OUTPUT FROM THE MODULATOR WITH A RELATIVE PHASE OF 90° COMPARED TO THE SUBCARRIER OUTPUT PRODUCED BY A SIGNAL AT PIN 4 (B-Y). THE MAGNITUDE OF THE CHROMINANCE SUBCARRIER OUTPUT IS DETERMINED BY THE DIFFERENCE IN DC LEVEL BETWEEN PIN 2 AND 3 (OR PIN 4 AND 3), WHERE PIN 3 IS DC BIASED AT A REFERENCE LEVEL. THE PHASE OF THE SUBCARRIER IS CHANGED BY 180° WHEN THE POLARITY OF THE SIGNAL AT PIN 2 (OR 4) IS CHANGED WITH RESPECT TO THAT AT PIN 3. WHEN SIMULTANEOUS SIGNALS EXIST AT PIN 2 AND 4, THE SUBCARRIER OUTPUT LEVEL AND PHASE WILL BE THE VECTOR SUM OF THE QUADRATURE COMPONENTS PRODUCED BY PIN 2 AND 4. THIS SUBCARRIER IS INTERNALLY CONNECTED TO PIN 13 FOR RF MODULATION.

L9 AND C11 FORM THE TANK CIRCUIT OF THE AUDIO SUBCARRIER OSCILLATOR. FREQUENCY DEVIATION IS ACHIEVED BY SWITCHING A SMALL VALUE - CAPACITOR TO GROUND. THIS IS DONE BY VARYING THE DC VOLTAGE TO THE ANODE OF THE VARACTOR DIODE.

THE LC NETWORKS CONNECTED TO PIN 10 AND 11 FORMS THE VESTIGIAL SIDEBAND FILTER OF CHANNEL 3 AND 4 RESPECTIVELY.

3.2.2 ELECTRICAL CHARACTERISTICS

3.2.2.1 ABSOLUTE MAXIMUM RATINGS.

THE MAXIMUM VOLTAGE APPLIED BETWEEN ANY PIN AND CASE SHOULD BE WITHIN - 18V TO +15V.

3.2.2.2 CHARACTERISTICS

A	18/8/78	D	TITLE	
B		E	INTERNAL PRODUCT SPECIFICATION	UM1291-1
C		F		
ASTEC INTERNATIONAL LIMITED HONG KONG				Sheet 4 of 21 A-4

A	18/8/78	D	TITLE
B		E	INTERNAL PRODUCT SPECIFICATION
C		F	
UM1291-1			
Sheet 13 of 21 A-4			

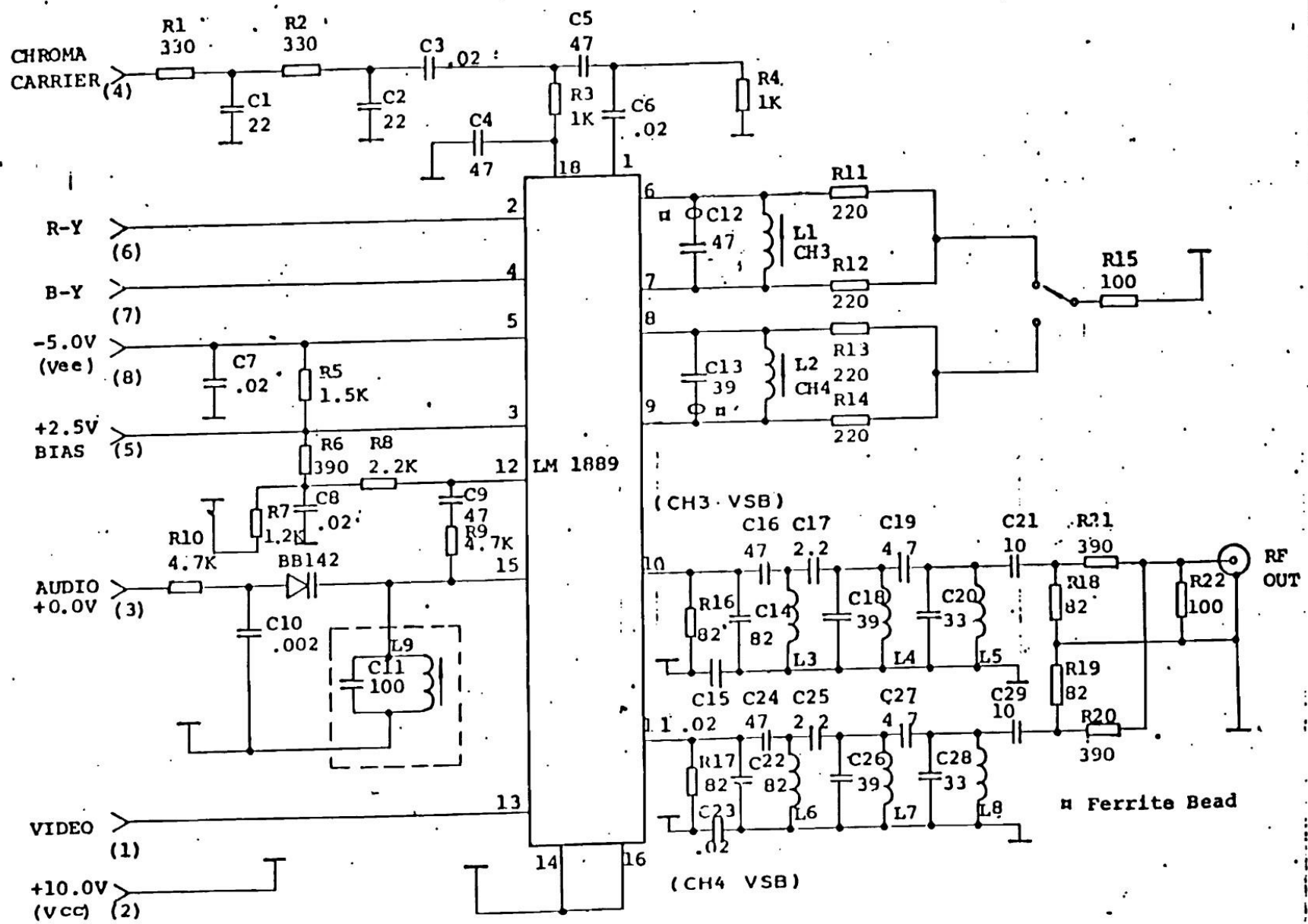

FIG.3 CIRCUIT DIAGRAM

3.2.2.4 ALIGNMENT CHART

STEP	COIL TO BE ADJUSTED	METHOD OF ADJUSTMENT	UNTIL THE FOLLOWING REQUIREMENT IS MET
CH3 1	L1	ADJUST BRASS SLUG	61.25MHZ.
CH4 2	L2	ADJUST BRASS SLUG	67.25MHZ.
CH3* 3	L9	ADJUST FERRITE CORE	4.5MHZ.
CH3 4A	L4	KNIFE THE COIL.	THE PASS BAND CENTRE IS MOVED TO 63.50MHZ.
B	L5	KNIFE THE COIL	THE PASS BAND IS AS FLAT AS POSSIBLE.
C	L3	KNIFE THE COIL	THE PASS BAND IS AS FLAT AS POSSIBLE.
D	L4	KNIFE THE COIL	THE PASS BAND IS WITHIN SPEC.
E	L5	KNIFE THE COIL	THE PASS BAND IS WITHIN SPEC.
CH4 5A	L7	KNIFE THE COIL	THE PASS BAND CENTRE IS MOVED TO 69.50MHZ.
B	L8	KNIFE THE COIL	THE PASS BAND IS AS FLAT AS POSSIBLE.
C	L6	KNIFE THE COIL	THE PASS BAND IS AS FLAT AS POSSIBLE.
D	L7	KNIFE THE COIL	THE PASS BAND IS WITHIN SPEC.
E	L8	KNIFE THE COIL	THE PASS BAND IS WITHIN SPEC.

* THE SOUND INPUT IS OFFSET TO +0.0V W.R.T. GROUND
SEE SHEET 18

A	18/8/78	D	TITLE INTERNAL PRODUCT SPECIFICATION	UM1291-1
B		E		
C		F		
ASTEC INTERNATIONAL LIMITED			HONG KONG	Sheet 6 of 21 A-4

THE MODULE IS DESIGNED TO WORK AT 2 SUPPLIES WHERE ONE IS +10V (VCC) WHILE THE OTHER IS - 5V (VEE). THE IC GROUND IS TIED TO - 5V WHILE THE IC SUPPLY IS +10V. THE MODULATION TRANSFER CHARACTERISTIC WILL BE NEGATIVE, I.E. A POSITIVE GOING SIGNAL INPUT WILL CAUSE A DECREASE IN RF OUTPUT LEVEL. THE PEAK RF OUTPUT IS DEFINED WITH INPUT GROUNDED (0V). FIG 4 DEFINES A TYPICAL TRANSFER CHARACTERISTIC. TABLE 1 DEFINES OTHER VARIOUS PARAMETERS THAT THE MODULATOR SHALL MEET.

3.2.2.3

ALIGNMENT PROCEDURE

A. CHANNEL FREQUENCY.

USING ZERO BEAT METHOD, L1 AND L2 IS ADJUSTED TO GIVE 61.25MHZ (CH3) AND 67.25MHZ (CH4) RESPECTIVELY.

B. SOUND SUBCARRIER.

USING ZERO BEAT METHOD, L9 IS ADJUSTED FOR 4.5MHZ SOUND SUBCARRIER FREQUENCY.

C. VSB FILTER.

FOR CH3, L3, L4, L5 ARE ADJUSTED REPEATEDLY TO HAVE THE PASS BAND CENTRE AT ABOUT 63.50MHZ. AND THE BAND EDGES AT 60MHZ AND 66MHZ.
FOR CH4, L6, L7, L8 ARE ADJUSTED REPEATEDLY TO HAVE THE PASS BAND CENTRE AT ABOUT 69.50MHZ AND THE BAND EDGES AT 66MHZ AND 72MHZ.

A	18/8/78	D		TITLE	
B		E		INTERNAL PRODUCT SPECIFICATION	UM1291-1
C		F			
ASTEC INTERNATIONAL LIMITED HONG KONG					Sheet 5 of 21 A-4